



# ULTIMA 500 SERIES

Owners Manual



[www.UltimaDentalSystems.com](http://www.UltimaDentalSystems.com)  
(888) 900-8584

Congratulations on the purchase of your new Ultima 500 air dental delivery unit. Our goal at Ultima Dental Systems is to provide the Veterinarian with the finest dental products and the best customer support available in the industry. All our equipment is built with a close attention to detail and a strong passion for quality. Ultima Dental Systems has specialized in dental air equipment exclusively for veterinarians since 1984 when we introduced the first dental unit for Veterinarians. Ultima Dental Systems is also the first dental manufacturer to introduce an enclosed dental cart system as well a dental unit with a built in Wet-table. We have offered quality products and services for over 30 years. So you can rest assured that you have purchased the finest Veterinary dental equipment available in the world today.

## **Your Ultima 500 unit has been tested, and operated to ensure the highest level of quality, before being delivered to you.**

1. To begin working with your Ultima 500, simply open the back door; **remove the shipping caps located on the air inlets of the compressor heads.** Store the shipping plugs somewhere secure, just in case you ever need to ship or store your unit without spilling oil from the compressor. You will damage the compressor by running the dental unit with the shipping caps secured to the pumps.

## **DO NOT RUN THE UNIT WITHOUT REMOVING THE SHIPPING CAPS**



**Screw on the air intake filters onto the same inlet hole**



Part # UD0167

2. Uncoil the electrical line and feed it through either one of two round grommets (openings located in the rear of the unit underneath the back door and on the bottom right side of the unit). **Use a dedicated outlet to plug the unit in.**

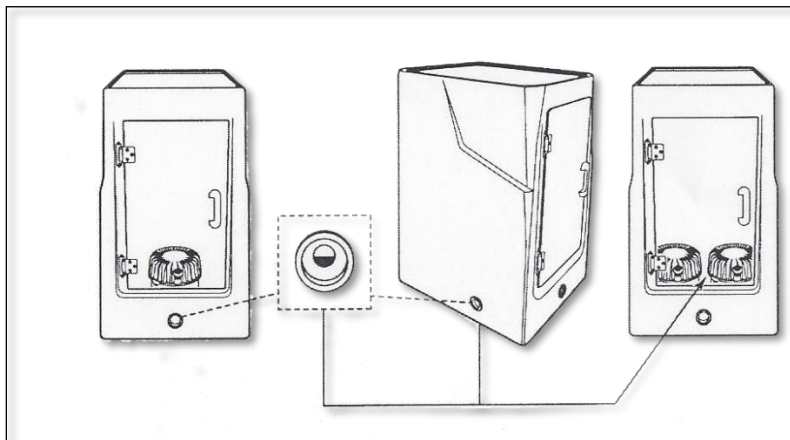

3. **Next remove the water bottles and fill them up with distilled water.** Since the unit has two water reservoirs you have the option of filling one of the water bottles with an antiseptic solution and the other with just distilled water. **\* If you choose to use an antiseptic solution please make sure to switch over to the bottle with distilled water and run the handpieces used. You must circulate water through those handpieces and tubing to avoid any clogs or blockage on the mechanical components in unit and tubing.\***

We recommend using Ultra Scale which inhibits bacteria. It also contains a special lubricant for scaling and cutting that removes biofilm that builds up in the patient's mouth and equipment. Ultra Scale also disinfects teeth while masking mouth odor and is Chlorhexidine-free which is ideal for the dental unit since it will not cause any blockage of the components or tubing. Simply mix with water and add directly to dental unit water bottle reservoir.



Part # 54270

4. To install handpieces, simply mate the rear end of the handpiece with the handpiece tubing connector, then hand tighten the silver Midwest connector.



5. Make sure the light on the power strip is on. Then adjust the pressure switch on the compressor to Auto to begin. Allow the compressor to build full pressure and then shut off before using any of the hand instruments, the compressor tank pressure gauge will read slightly below 120psi. The regulator in-line pressure gauge will read approximately between 65-70 psi.

***When the compressor reaches full pressure (120 psi reading on the tank pressure gauge) you will hear a 4 second burst of air. Do not be alarmed, this is the compressors auto drain system purging into the collection bottle located in the upper left hand corner on the inside of the unit. This will occur every time the unit reaches full pressure. What this does is not allow any moisture to build up in the 4-gallon holding tank. This feature is unique ONLY Ultima Dental units, every other Veterinary dental unit on the market requires that the compressor tank be manually drained to avoid the holding tank from rusting and rupturing.***



Ultima 1 HP Dual Pump Compressor – Part # 54071

# Table of Contents

1. Control Panel .....	Page 5-6
2. Handpieces .....	Page 7-8
3. Ultima Silent-Surge Compressor .....	Page 9-15
4. Compressor pump diagram .....	Page 13
5. Compressor frame diagram .....	Page 14
6. Compressor Trouble shooting Guide .....	Page 15
7. Piezo Scaler Guide.....	Page 16-19
8. General Info/ Trouble Shooting Guide .....	Page 20-25
9. Warranty .....	Page 26

# Control Panel

1. Located on the left side of the front control panel is a small black single screw. When removed this screw will allow the panel to open on its hinge like a door; allowing access to the units' panel components.
2. The on/off toggle switch allows you to turn the water on and off to handpieces.
3. The water volume knob is used to increase and decrease the flow of water to the handpieces.
4. The water bottle selector switch is used to switch back and forth between the two (2) water bottles. This is an excellent feature allowing you to fill each bottle with a different solution.

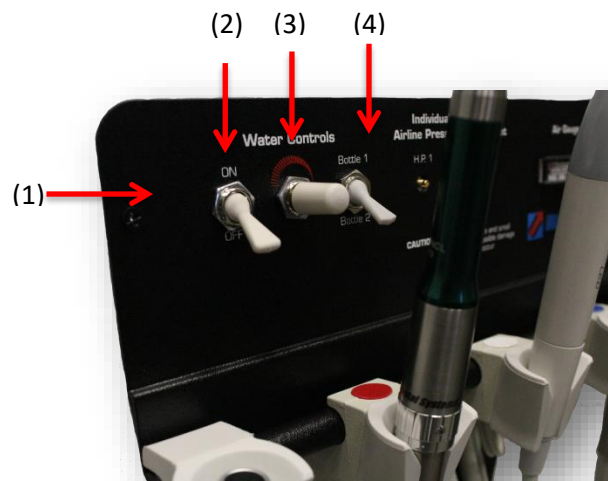

5. The individual handpiece airline pressure adjustment screws are used to make adjustments to and individual handpiece while they are running. The airlines have been preset at the factory.



**Continued Next Page**

6. The rectangular air gauge will show you the pressure of the handpiece that is running while in use.
7. If your unit is equipped with a Piezo Scaler on the upper right corner you will find the power dial for the Scaler.

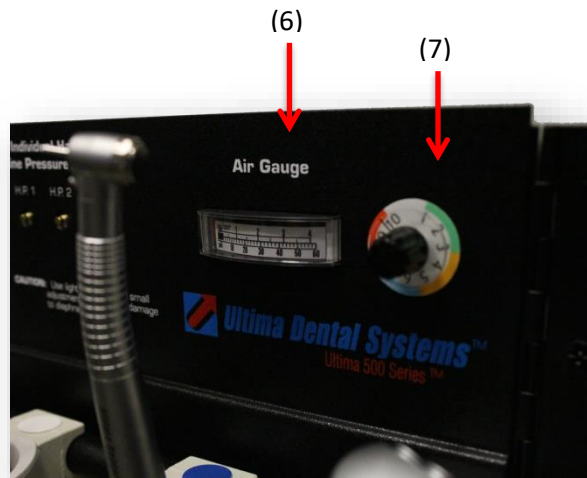

Visit [www.UltimaDentalSystems.com](http://www.UltimaDentalSystems.com) for helpful videos and tips on how to get the most out of your Ultima!

For technical assist or questions, simply call (888) 900-8584 and one of our knowledgeable customer support members will help you with what you need Monday through Friday 9am to 5pm Est.

# Handpieces

On the Ultima 500 only one handpiece can be run at a time. They are activated by an automatic holder when removed from its place. The handpiece must be placed in the same holder to de-activate the handpiece in order to allow another handpiece to function. The holders and handpiece tubing has been color coded for your convenience. Red is the low speed handpiece (Polisher), White is the accessories line or Piezo line if the unit is equipped with one, and Blue is for the highspeed drill. To run a handpiece simply remove it from the holder and step on the foot control pedal. Handpiece Pressures: HP 1. Red line (Polisher) should be set to 40 – 50 Psi, HP 2. White line is an accessories line and is not set, HP 3. Blue line (High speed drill) should be set to 32 Psi.

To install handpieces simply mate the rear end of the handpiece with the handpiece tubing connector.



1. The UDS lowspeed handpiece (Polisher) is and 4:1 E-style handpiece with a 20,000 Rpm motor. Meaning the 4:1 reduction nose cone brings the 20,000 rpm motor down to 5,000 rpm's for polishing. A 1:1 reduction nose cone or contra angle allows you to use the full 20,000 rpm's making it useful on procedures for small animals such as rabbits and other various rodents. This saves time and money because of its 2 in 1 feature.
2. If your unit is equipped with a Piezo Scaler built into the middle white accessories line do not worry about the pressure setting for this, as it is an electric Scaler and only uses air to turn a switch on and off.
3. If your unit is equipped with a fiber optic high speed drill note that it has an eighteen second delay. This is a great feature; the eighteen second time delay on the handpiece allows you to use the drill as a light wand.
4. If your unit is equipped with an LED highspeed drill, there is no time delay. The way the LED light gets powered is by an internal generator that spins when the foot control is pressed to operate the handpiece. Once the foot control is released and the flow of air stopped the light will shut off.
5. The 3-way syringe is used by depressing the right button for a burst of air, the left button for a stream of water, both buttons depressed will produce a mist.
6. Ultima 500 double compressor comes standard with a suction system that activates by pushing the silver button on the suction handpiece. The pick-up bottle is located inside the unit behind the water



bottle on the right side. To empty the collection bottle simply unscrew and dispose of the waste and reattach the bottle. IT IS EXTREMELY IMPORTANT NOT TO ALLOW THE COLLECTION BOTTLE TO OVER FLOW! To clean the suction system, run disinfectant cleaning solution or 10% solution of Clorox through the system.

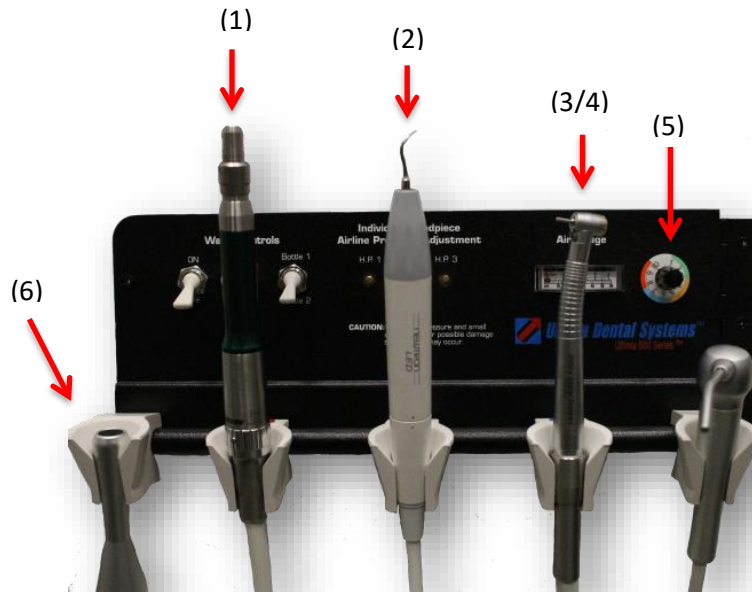

Visit [www.UltimaDentalSystems.com](http://www.UltimaDentalSystems.com) for helpful videos and tips on how to get the most out of your Ultima!

For technical assist or questions, simply call (888) 900-8584 and one of our knowledgeable customer support members will help you with what you need Monday through Friday 9am to 5pm Est.

# Ultima Silent-Surge Compressor

1. The air gauge to the left of the Off/Auto switch; the compressor in-line pressure gauge has been preset at the factory to 65-70 Psi. Do Not exceed 70 psi. The air gauge to the right of the Off/Auto switch is the tank pressure gauge. When the compressor on/off switch is set to auto it will build pressure to 120 psi. When the air in the holding tank drops down to 80 psi, the compressor will turn back on and bring the pressure in the holding tank back to 120 psi.

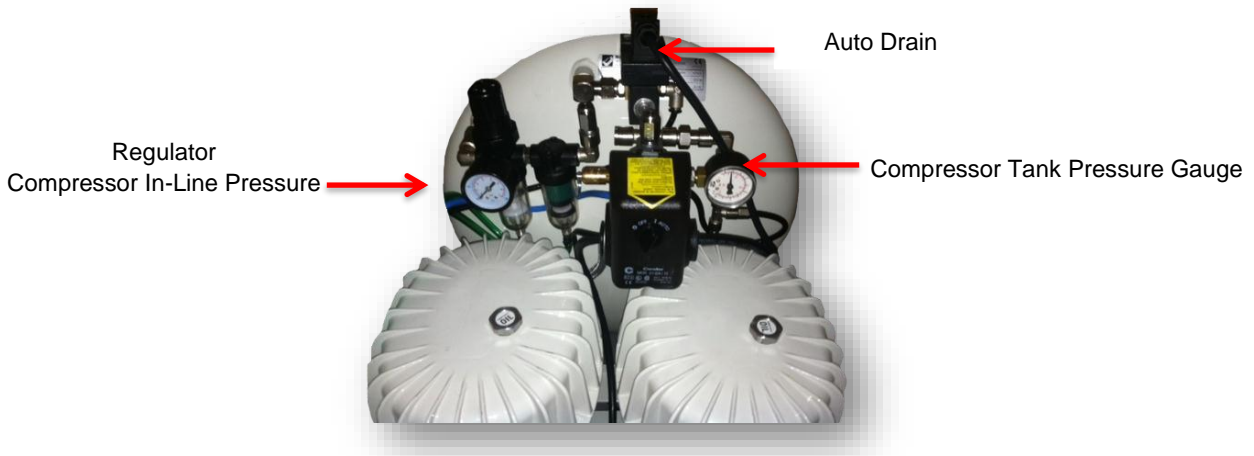

Ultima 1 HP Dual Pump Compressor – Part # 54071

2. The Ultima 500 is equipped with an Auto Drain system. The Auto Drain system automatically purges the air holding tank for two seconds for every thirty minutes the power to the unit is on. This feature significantly extends the working life of the compressor preventing rust inside the tank.
3. Older Ultima 500 model units have a manual T-shaped valve located on the compressor air tank at about the twelve o'clock position that must be drained once a week.



Manual Drain Release Valve – Part # UD0197

**Continued Next Page**

- The compressor collection bottle is located on the upper left corner inside the unit. This bottle needs to be empty and clean at all times. Allowing any amount of fluid to build up in the bottle will cause overspray on the inside of the unit. Schedule for emptying the pick up bottle varies from one user to the other, but should at the very minimum be emptied and cleaned at least once a week. To empty, just remove the bottle from the bracket, unscrew the bottle from the top, and dispose of the waste. Fluid inside of the collection bottle is not toxic and can be poured down the sink drain.



Compressor Collection Bottle - Part # UD0191

- Oil level on the unit should be checked regularly, this should be done before the unit is turned on. The oil should be changed once a year to validate warranty and ensure a long working life for the compressor.  
On the U500 single head pump unit: An access hole is located under the back door where the oil level sight glass is located.  
On the U500 Double head pump units: Oil level sight glass is located under the shelf on the side of the pumps. Oil level should be  $\frac{1}{2}$  to  $\frac{2}{3}$  full.  
The compressor pumps can be found underneath the white shelf inside the unit.

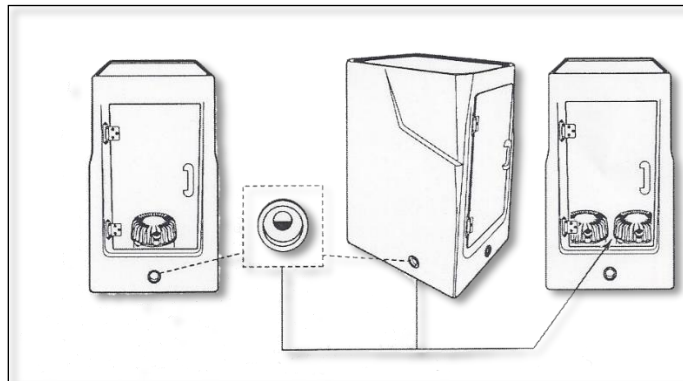

For Silent-Surge Oil or the Ultima Yearly Maintenance Kit Call Ultima Dental Systems at (888) 900-8584 or your local distributor.

The Yearly Maintenance Kit with pump includes: Two bottles 24oz bottles of Silent-Surge compressor oil, heavy duty pump to remove oil, four replacement air filter elements, and compressor regulator filters – Part # 54078



The Yearly Maintenance Kit without pump includes: Two bottles 24oz bottles of Silent-Surge compressor oil, four replacement air filter elements, and compressor regulator filters – Part # 54078P



6. The compressor regulator filters should be replaced once a year along with the yearly oil change.



Regulator Filter  
Part # UD0144



Coalescent Filter  
Part # UD0140

Visit [www.UltimaDentalSystems.com](http://www.UltimaDentalSystems.com) for helpful videos and tips on how to get the most out for your Ultima!

For technical assist or questions, simply call (888) 900-8584 and one of our knowledgeable customer support members will help you with what you need Monday through Friday 9am to 5pm Est.

# Compressor Pump Diagram

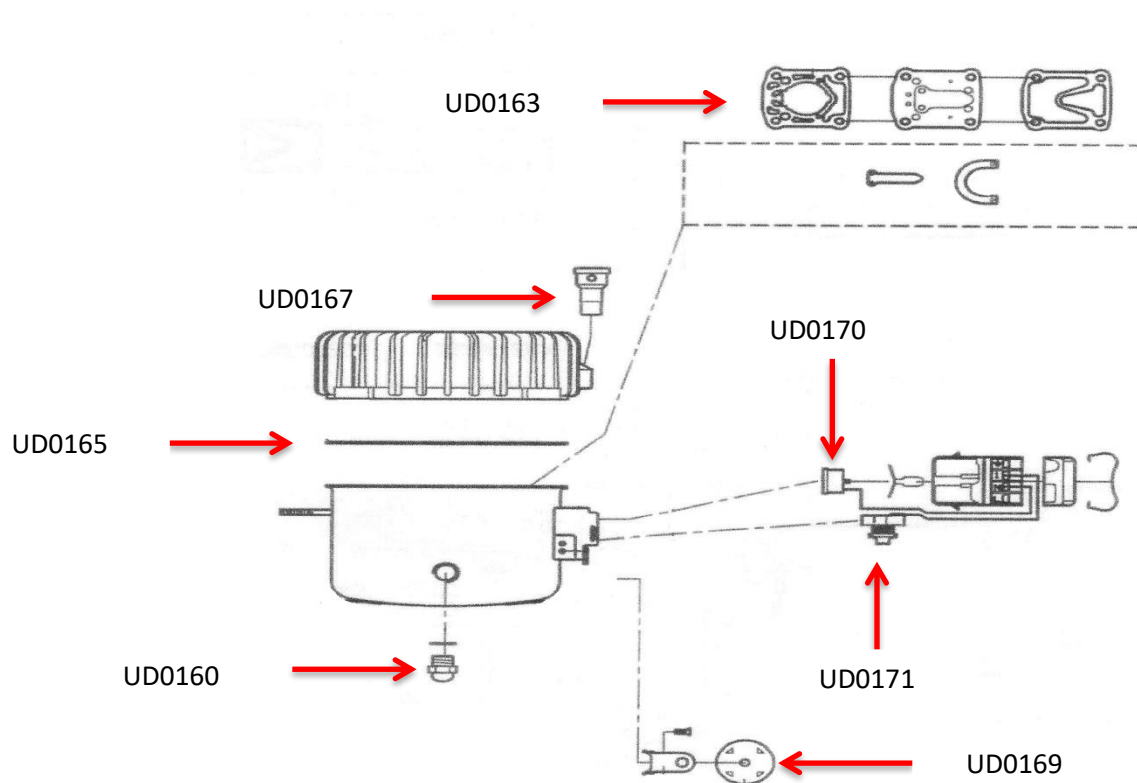

Visit [www.UltimaDentalSystems.com](http://www.UltimaDentalSystems.com) for helpful videos and tips on how to get the most out of your Ultima!

For technical assist or questions, simply call (888) 900-8584 and one of our knowledgeable customer support members will help you with what you need Monday through Friday 9am to 5pm Est.

# Compressor Frame Diagram

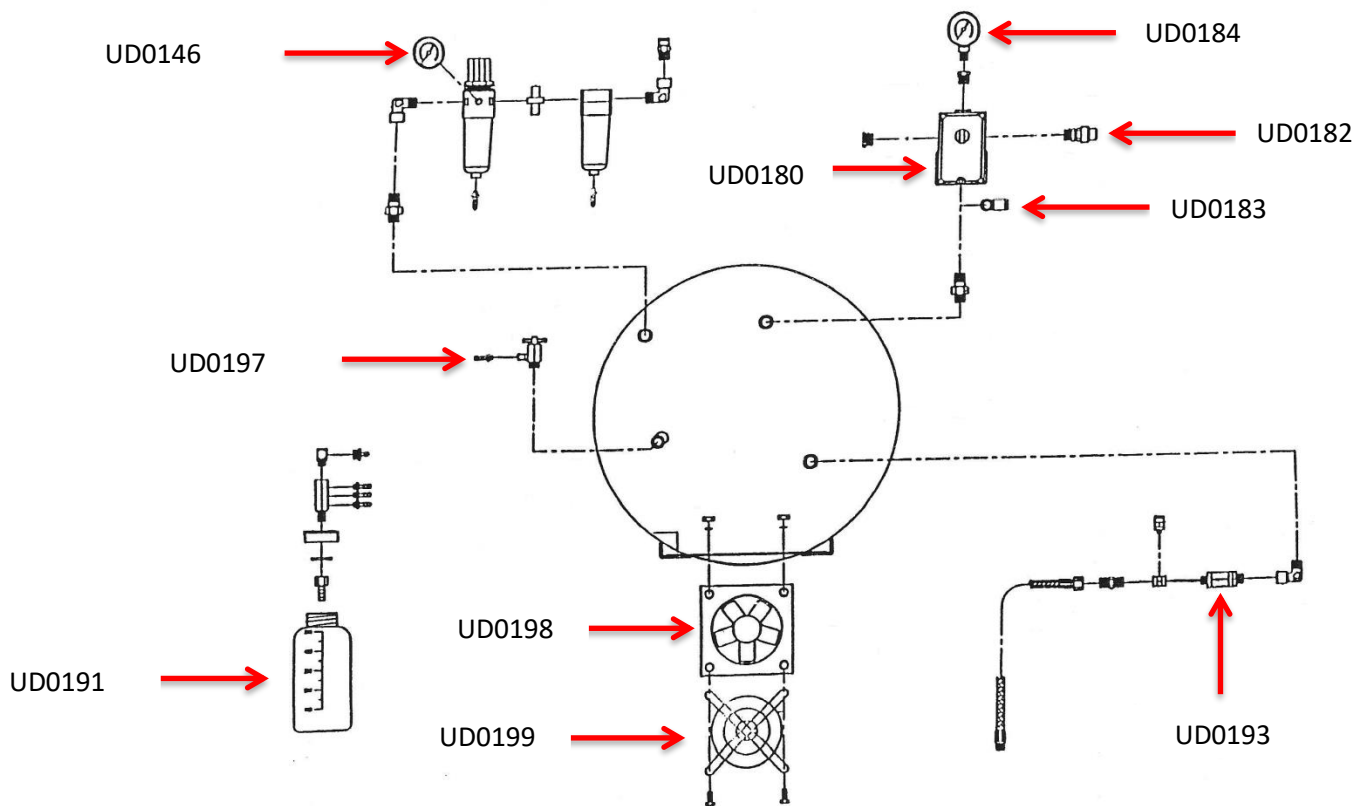

Visit [www.UltimaDentalSystems.com](http://www.UltimaDentalSystems.com) for helpful videos and tips on how to get the most out for your Ultima!

For technical assist or questions, simply call (888) 900-8584 and one of our knowledgeable customer support members will help you with what you need Monday through Friday 9am to 5pm Est.

# Helpful Compressor Tips

1. Always operate the compressor on a flat surface.
2. Check oil level and top off to mid level if needed. Oil sight glass should be ½ to ¾ full.
3. Use a properly grounded outlet that will except 3 prongs. DO NOT operate the compressor with a damaged cord.
4. Keep the compressor free of dust, animal fur and dirt. This will prolong air filter operation and prevent clogging of the safety relief valve.
5. DO NOT substitute or mix oil from other available brands. Any attempt to use other brands of oil will result in compressor breakdown and void all warranty.
6. Never attempt to service the compressor while plugged into an electrical outlet.
7. Avoid direct contact with the surface of the compressor after prolonged use, high temperatures may be present.
8. Use only factory authorized parts.

Fault Detected	Possible Cause	Solution
Compressor will not run	<ol style="list-style-type: none"> <li>1. No Power</li> <li>2. Bad cord connection</li> <li>3. Holding tank is pressurized</li> <li>4. Thermal overload protector has been tripped</li> </ol>	<ol style="list-style-type: none"> <li>1. Check outlet voltage, fuse and circuit breakers.</li> <li>2. Check cord connector for viable damage. If using an extension cord, make sure it is UL approved, it's heavy duty and grounded.</li> <li>3. Wait 15 minutes and try starting again.</li> <li>4. Call Ultima Dental Systems for additional assistance (888) 900-8584.</li> </ol>
Compressor runs but will not supply air	<ol style="list-style-type: none"> <li>1. Air pressure regulator is not set properly</li> <li>2. Air intake filter is clogged or not installed properly</li> <li>3. Extensive leak</li> </ol>	<ol style="list-style-type: none"> <li>1. Reset regulator pressure to 65-70 psi.</li> <li>2. Clean air intake filter or replace.</li> <li>3. Check all compressor fittings and connections on the dental unit. Close the pressure regulator all the way (Counter Clockwise) if pressure in the tank builds up, the leak is in the dental unit.</li> <li>4. Call Ultima Dental Systems for additional assistance (888) 900-8584.</li> </ol>
Rattling noise during operation	<ol style="list-style-type: none"> <li>1. Compressor motor is touching the frame</li> <li>2. Fan is loose or damaged</li> </ol>	<ol style="list-style-type: none"> <li>1. Operate on level surface, check oil level and adjust if necessary</li> <li>2. Inspect the fan on the bottom of the compressor, make sure it is tightly secured to the frame. If tightly secured, possible bearing damage, replace fan.</li> <li>3. Call Ultima Dental Systems for additional assistance (888) 900-8584.</li> </ol>
Milky oil in compressor	<ol style="list-style-type: none"> <li>1. Oil has been contaminated with moisture or other foreign matter.</li> </ol>	<ol style="list-style-type: none"> <li>1. Change oil. Oil needs to be changed once a year. Use only oil from Ultima Dental Systems Part # UD0161.</li> <li>2. Call Ultima Dental Systems for additional assistance (888) 900-8584.</li> </ol>
Air holding tank is not holding pressure when the compressor is not running	<ol style="list-style-type: none"> <li>1. Air leak</li> <li>2. Faulty Check Valve</li> </ol>	<ol style="list-style-type: none"> <li>1. Spray all connections with soap solution to determine the location of the leak. Reseal or replace leaking part(s).</li> <li>2. Clean or replace faulty check valve.</li> <li>3. Call Ultima Dental Systems for additional assistance (888) 900-8584.</li> </ol>
No air pressure shown on regulator gauge	<ol style="list-style-type: none"> <li>1. Regulator has not been set and adjusted</li> <li>2. Regulator is faulty</li> </ol>	<ol style="list-style-type: none"> <li>1. List knob and turn clockwise until gauge shows required pressure (65-70 psi).</li> <li>2. Replace faulty regulator assembly (Part # UD0142).</li> </ol>



# Piezo Scaler Quick Reference Guide

## Magnetostrictive vs Piezo Electric Scalers

### What's the difference?

Developed In the 1950's, Magnetostrictive units (cavitron style) vibrate a tip (insert) at either 25k or 35k (cps). The handpiece of a magnetostrictive ultrasonic is hard wired into the ultrasonic unit, therefore it is not detachable nor autoclavable.

The tip is attached to several long metallic stacks. These stacks are inserted into the handpiece. Under the handpiece and surrounding the metal stacks are several coiled wires which when excited by electricity give a vibration to the insert's stacked metal plates caused by a "magnetic field" which is produced. The tip of the insert vibrates in an elliptical motion.

The handpiece generates a tremendous amount of heat, which requires a high volume of water to constantly run through the hand piece to keep it cool. This excessive amount of water causes the practitioner poor visibility. IT BASICALLY WORKS LIKE A JACK-HAMMER.

Piezo was first developed in 1972 by SATELEC. The handpieces are detachable and autoclavable. Inside the hand piece is the "transducer". The transducer consists of ceramic disks stacked next to one another. These ceramic disks have high quartz content and when excited with electricity they compress and decompress causing a controlled vibration, the result is an ultrasonic vibration in a linear motion (forward and backward) on the same plane as the handpiece.

There is very little to no heat generated in the handpiece requiring a minimal amount of water, which means better visibility for the practitioner and a dryer patient. The water from the tip flushes removed deposits and is required for "the cavitation effect" to de-bridge bio-film.

The linear tip motion is also more efficient and more comfortable. When the magnetostrictive tip vibrates, it bangs on the surface of the tooth to knock calculus off in chunks, where as a piezo tip vibrates linearly so the tip works along the tooth surface, shaving calculus off in sheets. Satelec piezo ultrasonic scalers also leave the tooth surface smoother than other ultrasonic scalers, sonic scaler, and hand instrumentation.

Visit [www.UltimaDentalSystems.com](http://www.UltimaDentalSystems.com) for helpful videos and tips on how to get the most out of your Ultima!

For technical assist or questions, simply call (888) 900-8584 and one of our knowledgeable customer support members will help you with what you need Monday through Friday 9am to 5pm Est.



#1 Universal – Part 54121



#2 Heavy Scaling – Part # 54122

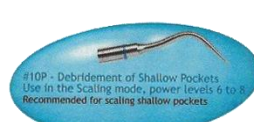

10P Perio – Part # 54130



Potentiometer Faceplate

Ultima dental units with built in Satelec piezo scaler come standard with 3 scaling tips. The #1 Universal tip is recommended for simple cases and gross debridement. The #2 tip is recommended for the removal of heavy calculus and the 10P tip is recommended for scaling shallow pockets. Satelec offers over 70 different tips that require different levels of power. This is why the Potentiometer (Power Dial Knob) is numbered 1-10 and is color coded. The scaling tips that come standard with your Ultima unit are color coded blue and should be operated in the blue zone between 6 and 8.

Most likely, you are coming from years of working with a cavitron or similar magnetorestrictive type unit. If that is the case you are in for a very pleasant surprise.

### Water Flow

Cavitron user are accustomed to heavy water spray. With piezo technology, the handpiece doesn't heat up so only the tip requires cooling reducing the amount of water used tremendously.

#### Adjusted the Water Flow

1. Screw on the #1 tip (Universal) onto the handpiece until it is hand tight. Then use the scaler tip wrench provided and give it an extra half turn to securely tighten the tip. **When screwing the tip onto the handpiece ensure that it is screwing on smoothly, if the tip is not screwing on smoothly do not force it, otherwise you will end up cross threading the handpiece and tip. Use care when tightening the tips, excessive torque may cause damage to the tip and/or handpiece.**
2. Turn the power control dial down to its lowest setting.
3. Flip the water control switch to the ON position. Using the water flow knob, start to “inch” it up slowly until you get a drop rate of about 2-3 drops of water per second.
4. Turn the power control dial up to its intended operating range, which in this case would be the Blue zone. You'll be pleasantly surprised to find that 2-3 drops of water is all that you need. This small amount of water creates a very fine mist which produces a “halo” effect around the tip providing improved visibility for the technician.

## Technique

Cavitron users are accustomed to utilizing magnetorestrictive tip differently from the way a Satelec tip should be used. With the elliptical motion a cavitron provides, the technician is accustomed to using the front, side or back of the tip to bang the tooth to remove calculus. With piezo the process is different because the tip vibrates on the same plane as the handpiece. The tip moves forward and back, making the lateral side of the tip extremely efficient for shaving calculus. This stroke is a mirror image of hand instrumentation, with extraordinary results achieved, requiring only very little pressure resulting in no hand fatigue.

## Maintenance and Preventive Care

### Tips

Only Satelec tips should be used. Use of other manufacturer's tips will result in poor performance and/or damage to the scaler handpiece. Care should be exercised when tightening tips on the handpiece. Excessive torque may cause damage to the tip and/or handpiece.

### Tips without water ports

Use of tips without water ports can cause water to leak into the handpiece damaging it. User must turn off water when using a tip without a water port.

### Handpiece and tubing

If using irrigating fluids other than water, the cord and handpiece should be flushed out with distilled water for at least one minute. The handpiece should be disconnected from the cord after use. Dry the connector end of the handpiece and the handpiece tubing with air using the 3 way syringe on the dental unit. This will avoid moisture and dirt from accumulating which may cause problems with the connectors.

### Handpiece tubing

During normal use the handpiece tubing should not require any maintenance. Care should be exercised to avoid stepping on or rolling over the cord with the dental unit, as this can cause damage to the wires and hoses inside. The handpiece tubing may be cleaned with a cloth moistened with alcohol only.

### Handpiece cleaning

Remove tips from handpiece. Wipe the casing with a cloth moistened with alcohol. Place the handpiece in an autoclave pouch. Autoclave cycles will vary and it is recommended to consult your autoclave manufacturer for sterilization cycle recommendations.

The Satelec handpiece can withstand the following temperatures and pressures:

134 degrees Celsius, 2 bar for 20 minutes

121 degrees Celsius, 1 bar for 40 minutes

Chemclaving of the handpiece is not recommended and may shorten the life of the handpiece.

The handpiece should not be cold sterilized or submerged in any liquid as it will damage the handpiece.

### Handpiece maintenance

The small o-ring on the handpiece should be inspected on a regular basis. If the o-ring is damaged it should be replaced. The small o-ring should be replaced every six months, or every two to three months if the handpiece is regularly autoclaved. An installation tool and three extra o-rings are provided in the handpiece box. Additional o-rings may be ordered using Part # 54138. The large o-ring should not require replacement during normal service. If the large o-ring should become damaged a replacement may be obtained using Part # 54136.

### Warranty

Satelec piezo scaler are covered under warranty for 1 year following the date of purchase against defects in material or workmanship. A copy of an invoice is required as proof of date of purchase. Warranty is void if it is determined that the product has sustained malicious or deliberate damage. Tips have a 90 day limited warranty.



Standard Satelec Handpiece – Part # 54086



LED Satelec Handpiece – Part # 54082

## Piezo Scaler Quick Reference Guide

Fault Detected	Possible Causes	Solution
Handpiece does not vibrate	<ol style="list-style-type: none"> <li>1. Faulty handpiece cord &amp; connector</li> <li>2. Scaler cord wire cut</li> <li>3. Handpiece damaged</li> <li>4. Electrical contacts on cord are loose</li> <li>5. Tip worn or distorted</li> </ol>	<ol style="list-style-type: none"> <li>1. Unplug the scaler unit and wait 30 seconds to reset the scaler module</li> <li>2. Replace tip, worn tips will not allow the scaler to function properly</li> <li>3. Visit <a href="http://www.UltimaDentalSystems.com">www.UltimaDentalSystems.com</a> to watch the instructional video on how to remove the scaler you're your Ultima 500 series dental unit. Contact the UDS Technical support team for further instructions on where to send the scaler in for repair (888) 900-8584</li> </ol>
Weak Vibration	<ol style="list-style-type: none"> <li>1. Tip worn or distorted</li> <li>2. Tip over tighten</li> <li>3. Incorrect use</li> <li>4. Fluid in the cord connector</li> </ol>	<ol style="list-style-type: none"> <li>1. Replace the tip/Check tip chart to see if worn</li> <li>2. Tighten the tip using the tip wrench</li> <li>3. Dry electrical contacts</li> </ol>
Fluid leakage between hand piece and cord	<ol style="list-style-type: none"> <li>1. Worn small water o-ring</li> <li>2. Worn large handpiece o-ring</li> </ol>	<ol style="list-style-type: none"> <li>1. Check the small water o-ring on the bottom of the handpiece near the connector for damage. Replace if needed using Part # 54138</li> <li>2. Check the large handpiece o-ring on the bottom of the handpiece on the outer perimeter. Replace the o-ring if needed using Part # 54136</li> </ol>
No light (L.E.D model only)	<ol style="list-style-type: none"> <li>1. Faulty L.E.D ring</li> <li>2. Faulty handpiece/cord connector contacts</li> </ol>	<ol style="list-style-type: none"> <li>1. Clean the L.E.D ring contacts/ Replace L.E.D ring</li> <li>2. Clean the hand piece / cord connector contacts</li> <li>3. For further assistance call the UDS Technical support team: (888) 900-8584</li> </ol>

# Basic Trouble Shooting Guide

## **No water - Scaler/High-speed Drill**

1. Check the water on/off toggle switch and make sure it is in the on position.
2. Check the water increase/decrease knob and make sure it is turned up.
3. Grab the 3-way syringe and check to see if you get water from the handpiece.
4. Inspect the water bottles. Check for air leaks around the water bottles and make sure their secured tightly to the pressure head.
5. Squeeze the bottles to make sure they pressurized; the bottles should be rock hard.

If no water continues to be the issue, the problem may be more involved and may require a professional dental equipment technician. Other causes of no water issues could involve the blockage, failure, or damage of the water relay, control block, control block diaphragm, or the distribution block.

To determine the exact cause of the issue and to schedule an in-office visit by a certified technician Call Pro Repair Service: 1-800-645-6594. For all other general questions contact the UDS Technical Support team: (888) 900-8584.

Please check with the local dental Repair Service or equipment distributor in your area if you wish to schedule an in-office visit outside of the U.S.A.

# Basic Trouble Shooting Guide

## Polisher

Fault Detected	Possible Causes	Solution
The prophy angle does not spin	<ol style="list-style-type: none"> <li>1. The prophy is faulty or damaged</li> <li>2. The gear dial is set to the incorrect position</li> <li>3. The polisher motor is ceased</li> </ol>	<ol style="list-style-type: none"> <li>1. Replace the prophy angle. The bearings on metal prophy angles often go bad and need to be replaced. We recommend using Crosstex disposable prophy angles to prevent costly repairs (Part # UD0311).</li> <li>2. Make sure the polisher motor is set to the correct gear. If the motor is set to the neutral position, the prophy angle will not spin. (See Picture Below)</li> <li>3. Try oiling the polisher to break free the ceased motor. Watch the instruction video at <a href="http://www.UltimaDentalSystems.com">www.UltimaDentalSystems.com</a>.</li> </ol>
The prophy angle will not seat properly onto the polisher nose cone	<ol style="list-style-type: none"> <li>1. Faulty or damaged nose cone chuck</li> <li>2. Prophy angle stem has broken inside of the nose</li> </ol>	<ol style="list-style-type: none"> <li>1. The nose cone chuck will need to be repaired or replaced. Contact Ultima Dental Systems to send in your handpiece in for repair and receive a loaner handpiece while you wait, call (888) 900-8584.</li> <li>2. The prophy angle stem needs to be removed from the nose cone chuck, this requires disassembling the polisher nose cone. Contact Ultima Dental Systems to send in your handpiece in for repair and receive a loaner handpiece while you wait, call (888) 900-8584.</li> </ol>
The polisher seems weak and lacks power	<ol style="list-style-type: none"> <li>1. The pressure is not set correctly for the polisher handpiece</li> </ol>	<ol style="list-style-type: none"> <li>1. Polisher pressure should be between 40-50 Psi. Adjust gold screw that reads HP 1 on the front panel if needed. When adjusting, the pressure turn the screw slowly to avoid damaging the control block diaphragm.</li> </ol>

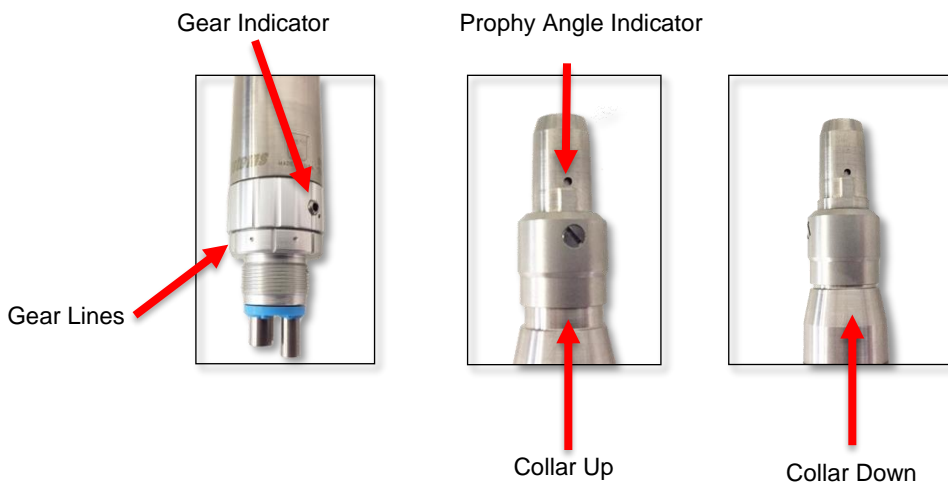

## Polisher

Oil the polisher to ensure the inside components are lubricated. To oil the polisher disconnect the handpiece from the tubing, you will notice four metal barbs on the bottom of the polisher. Two small barbs and two big barbs, place two to three drops of handpiece oil into the smaller of the two larger barbs. Re-connect the handpiece and run it upside down for thirty seconds to allow the oil to travel through the polisher. It is important that the polisher be run upside to avoid the thin handpiece oil from sliding back down the handpiece tubing.



Crosstex Disposable Prophylaxis Angles 100 Ct Part # UD0311



Handpiece Oil Pen Part # UD0300

Visit [www.UltimaDentalSystems.com](http://www.UltimaDentalSystems.com) for helpful videos and tips on how to get the most out for your Ultima!

For technical assist or questions, simply call (888) 900-8584 and one of our knowledgeable customer support members will help you with what you need Monday through Friday 9am to 5pm Est.

# Basic Trouble Shooting Guide

## High-speed Drill

Fault Detected	Possible Causes	Solution
The drill will not spin	<ol style="list-style-type: none"> <li>1. Blockage in the air line (Handpiece tubing)</li> <li>2. Pressure is not set correctly</li> <li>3. Damaged turbine</li> </ol>	<ol style="list-style-type: none"> <li>1. Disconnect the handpiece from the tubing. Step on the foot pedal to ensure air is flowing through the tubing. If air is flowing through the tubing it is likely that the turbine is damaged. If no air is flowing through the tubing, there is a blockage somewhere in the dental unit. A further in depth inspection is necessary, contact the UDS technical support team at (888) 900-8584 or Henry Schein Pro Repair service to schedule an in-office visit at (800) 645-6594.</li> <li>2. Make sure the pressure from the regulator is set properly (65-70 psi). Next ensure the pressure is set correctly on the control panel, adjust HP 3 to 32 psi.</li> <li>3. Spin the drill bur with your fingers, it should spin freely. If this is not the case, oil the handpiece to ensure the turbine is properly lubricated. If this does not solve the issue of the drill not spinning, a new turbine may be required. For a push button drill use part # UD0301. For a standard non-push button drill use part # UD0302. If you have any questions, please call (888) 900-8584 to speak with a knowledgeable Ultima dental technician.</li> </ol>
The drill bur is stuck and will not come out	<ol style="list-style-type: none"> <li>1. The turbine inside the drill is most likely damaged and needs to be replaced.</li> </ol>	<ol style="list-style-type: none"> <li>1. Remove the end cap located on the back of the drill. Check for debris, this is a sign that parts inside the turbine, such as the bearings, may have come loose causing the turbine not to function properly. Remove the turbine and try to manual remove the bur, if the bur is lodged in there and can't be removed replace the turbine. For a push button drill use part # UD0301. For a standard non-push button drill use part # UD0302. If you have any questions, please call (888) 900-8584 to speak with a knowledgeable Ultima dental technician.</li> </ol>
The drill keeps spitting out the bur	<ol style="list-style-type: none"> <li>1. The turbine inside the drill is most likely damaged and needs to be replaced.</li> </ol>	<ol style="list-style-type: none"> <li>1. Remove the end cap located on the back of the drill. Check for debris inside of the drill head, this is a sign that parts inside the turbine, such as the bearings, may have come loose causing the turbine not to function properly. If you have any questions, please call (888) 900-8584 to speak with a knowledgeable Ultima dental technician.</li> </ol>
Air is coming from the bottom of the handpiece, where it connects to the tubing	<ol style="list-style-type: none"> <li>1. Damaged handpiece gasket</li> <li>2. Hole or tear in the handpiece tubing</li> </ol>	<ol style="list-style-type: none"> <li>1. Remove the handpiece from the tubing and inspect the gasket on the bottom of the handpiece for any damage. If the gasket is damaged replace it using Part # UD0310 for a 5 hole handpiece gasket, commonly used on fiber optic handpieces. Use Part # UD0315 to order a 4 hole handpiece gasket. If you have any questions, please call (888) 900-8584 to speak with a knowledgeable Ultima dental technician.</li> </ol>



## Lubricating the High-speed Drill

To oil the drill simply turn it upside down. On the bottom of the drill there are four metal barbs, two small barbs and two big ones. Add two to three drops of handpiece oil to the smaller of the two larger barbs located on the bottom of the drill. Re-attach the hand piece and run the drill upside down for thirty second to a minute to allow the oil to circulate through the drill. Turning the handpiece upright will cause the oil to run down the tubing and will not lubricate the drill correctly.



Place 2-3 drops of handpiece oil in the smaller of the two larger metal barbs



Push Button Drill Part # 54150



Push Button Handpiece Gasket

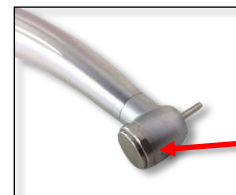

Drill End Cap

## High-speed Drill Turbines



Standard Turbine Part # UD0302



Push Button Turbine Part # UD0301



TEK USA T64 LED Drill



T64 Turbine Part # UD0303

The TEK USA LED high-speed drill is a discontinued item and is no longer available for purchase. Replacement spare parts for T64 highspeed drills are still available for purchase. If you have any questions or need assistance ordering parts for T64 highspeed drills contact Ultima Dental Systems at (888) 900-8584.



TEK USA T65 LED Drill Part # 54162



T65 Turbine Part # UD0304

# Warranty

- 5 year defective parts and technical support warranty. All parts on the unit are covered for 5 years if defective.
- The Fiber Glass and Aluminum shells for the dental units are only covered under warranty if defective out of the box and damaged during shipping.
- All parts on Ultima compressors are covered for 5 years if defective.
- The Lowspeed Polisher is covered under warranty for 1 year if defective.
- The Highspeed drill is covered under warranty for 1 year if defective - The turbine is covered under warranty for 6 months if defective.
- The Piezo scaler is covered under warranty for 1 year if defective.
- Labor and shipping is not included.